

Special Tools Required	■ Special tool to loosen crimp connections	4931 368 058
	■ Service crimping tool	4931 325 613

Important! ■ Before all repair work, pull the power plug from the socket!

General

General

The cable SEC 4 / SEC 10 is the connection between Angle Grinder SAG 3-180/ SAG 3-320 and Powerbox SPB 3.

The cable is made up of a seven-core connection lead, one cable plug, and one cable outlet. The length of the cable is 4m or 10m, depending on the type.

Both cable outlet and cable plug are type Amphenol C16-1.

The contact pins of the cable plug and the contact socket of the cable outlet are crimp constructions with strain relief.

Crimping technology

Technical information on crimping technology

A crimp connection is a non-detachable, electrical connection between one or more conductors with a crimp contact of any form made with aid of crimping technology.

With crimp profiles which exactly match the crimp barrel and the conductor cross-section, good electrical connections are made through pressure and specific deformations.

Advantages of crimp connections

The advantages are:

- rational processing of the contacts in any production scope
- processing with fully- or semi-automatic crimping machines or with hand crimping tools (electrically, pneumatically, or hydraulically driven)
- no cold soldering joints
- no impairment of the spring characteristics in the plug area due to soldering heat
- no danger to health caused by heavy metal and flux vapours
- maintenance of the conductor's flexibility behind the crimp connection
- no burnt, stained, or worn conductor insulations
- evenly good connection with reproducible electrical and mechanical values

Open crimp barrels

Contacts with open crimp barrels are open before crimping (e.g. u- or v-shaped). Preferably they are bandoleered contacts with separating straps allocated side-by-side or end-to-end. The crimping procedure closes the crimp barrel and at the same time separates the contact from the band.

Contacts with open crimp barrels can be obtained with or without insulating mounting. The main characteristic of the insulating mounting is a second crimp barrel (claw) which encircles the end of the insulating cover of the lead.

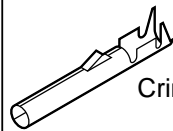

Crimp barrel (4931 325 615)

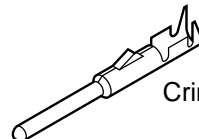

Crimp plug (4931 325 537)

The insulating mounting serves to keep the crimp connection free of mechanical strains like vibrations, bending load, collapsing stress, or tension load.

Crimp connections

The following characteristics serve to ensure a perfect crimp connection which will meet all electric and mechanic demands:

- allocation of all usable conductor cross-sections to the crimping height
- crimp barrel shape (sheet thickness, length, etc.)
- crimp profiles (crimping width)
- conductor crimping height and
- shaping of the insulating mounting.

Before making crimp connections

When making crimp connections, the manufacturer's instructions must be observed. They usually contain the following information:

- hints on handling
- allocation of contacts to the crimp profile of the hand crimping tool (in case of several crimp profiles)
- allocation of bandoleered contacts to the tool of the crimping machine
- conductor cross-sections of the contact
- diameter area of the conductor insulation.

Disassembly/Assembly**Stripping the insulation of the cable**

- 1** Always completely replace a defective cable outlet (1) and a defective cable plug (4).
- 2** First, remove the damaged cable outlet (1) and/or the cable plug (4) from the cable with aid of a knife (5) or similar.
- 3** Carefully strip the cable covering (3) by 2.5 cm.
 - ☞ Take care that the insulation of the cable leads (2) is not damaged.

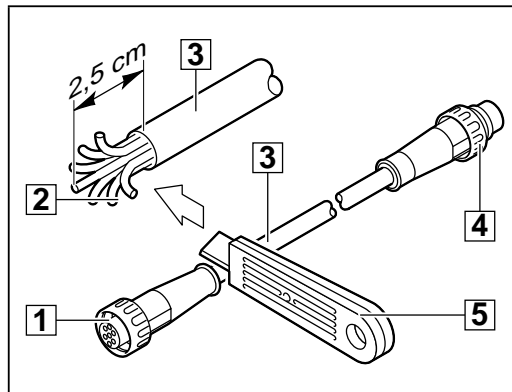

1

Stripping the insulation of the conductors

- 1** It is important to proceed very carefully when stripping the insulation of the conductor (G) in order to avoid any mistakes.
- 2** The stripping length (H) must be chosen such that in crimped condition
 - ☞ the conductor (G) and its insulating covering (E) are visible between conductor crimp (B) and insulation mounting (F) and
 - ☞ a projecting length (C) is ensured. The plug and connecting area must not be influenced by this.
- 3** The stripping length (H) of the conductors is $3.5 + 0.5$ mm both for conductor cross-sections of 0.75 mm^2 and 1.5 mm^2 .
- 4** The crimp measure (A) (norm) for Ampenol contacts is between 1.34 and 1.4 mm for conductor cross-sections of 0.75 mm^2 and between 1.4 and 1.55 mm for conductor cross-sections of 1.5 mm^2 .

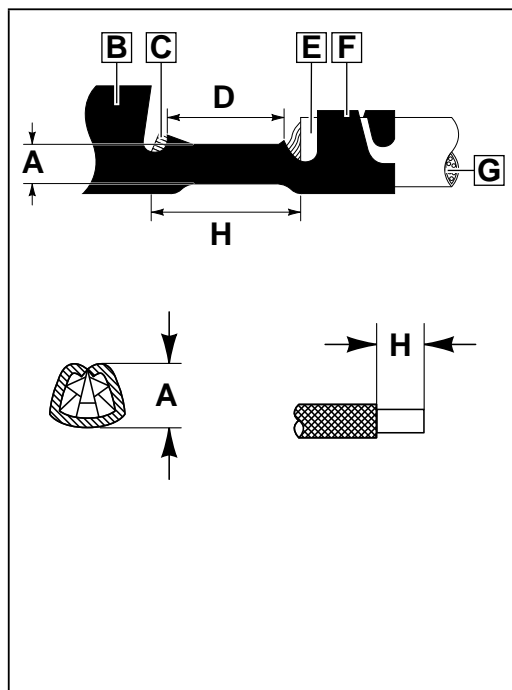

2

Crimping tool

- 1 For crimping the service crimping tool (3) must be used.
- 2 The crimping tool (3) has two different crimp profiles with the markings (1) and (2).
- 3 For conductor cross-sections of 0.14 - 0.5 mm² the yellow marking (1) applies and for conductor cross-sections of 0.5 - 1.5 mm² the red marking (2) applies.
 The red marking (2) is decisive for the cable SEC 4 / SEC 10.
- 4 Due to the spring clamping plate (4) a contact lock and contact positioning of the conductor takes place.

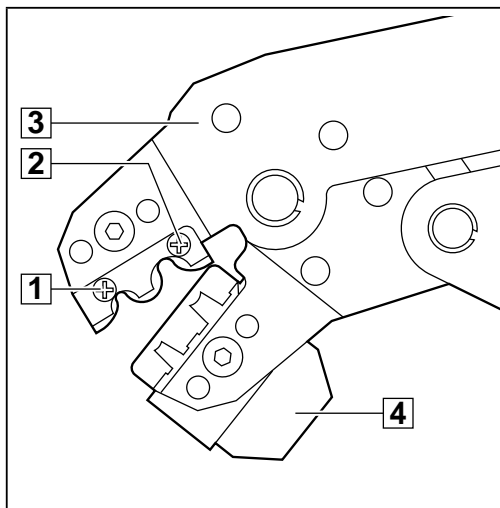

3

Crimping process

- 1 Push the crimp barrel (3) over the stripped lead (2).
- 2 Open the crimping tool (1) (service tool).
- 3 Push up the clamping plate of the crimping tool (1) and keep up the tension.
- 4 Lead the stripped lead (2) with the crimp barrel (3) through the clamping plate until the claw of the crimp barrel (3) is flush with the right section (red marking).
- 5 Release the clamping plate of the crimping tool (1) so that the stripped lead (2) is locked with the crimp barrel (3).
- 6 Press the handles of the crimping tool (1) together until the safety lock is released.
- 7 Push up the clamping plate of the crimping tool and remove the crimped lead.
- 8 Illustration 4 shows the complete crimping procedure (A to C).

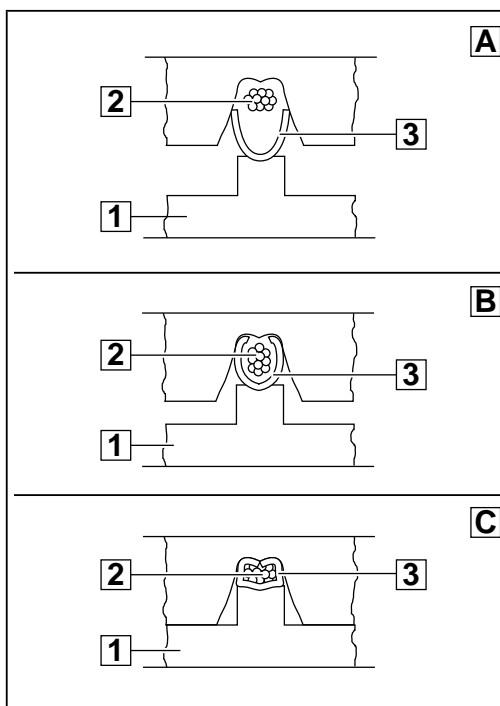

4

Correct crimp connection

- 1 Illustration 5 shows the area of a correctly crimped contact.
- 2 The conductor (2) and the insulating covering (1) are visible.
- 3 The projective length must not exceed max. 1 mm.

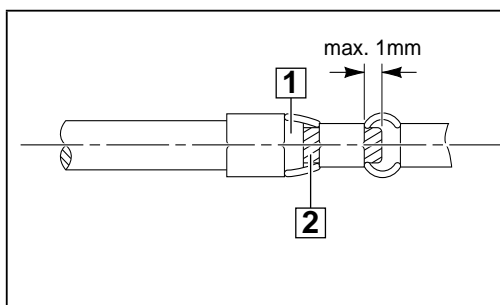

5

Faulty crimp connections

☞ Faulty crimp connections must be avoided by all means. The most common faults are:

- 1 Case A:** The conductor was stripped too much. The insulation is not visible anymore. Therefore the insulation mounting is useless.
- 2 Case B:** The conductor was not stripped enough. The end of the conductor is not visible anymore. Therefore the conductor crimp is useless.
- 3 Case C:** The conductor insulation reaches into the crimping area. Therefore the conductor crimp is useless.
- 4 Case D:** Single wires are inside the insulating mounting. The conductor crimp is also useless. There is the danger of short circuit.
- 5 Case E:** Free single wires are outside the crimp area. There is also the danger of a short circuit.

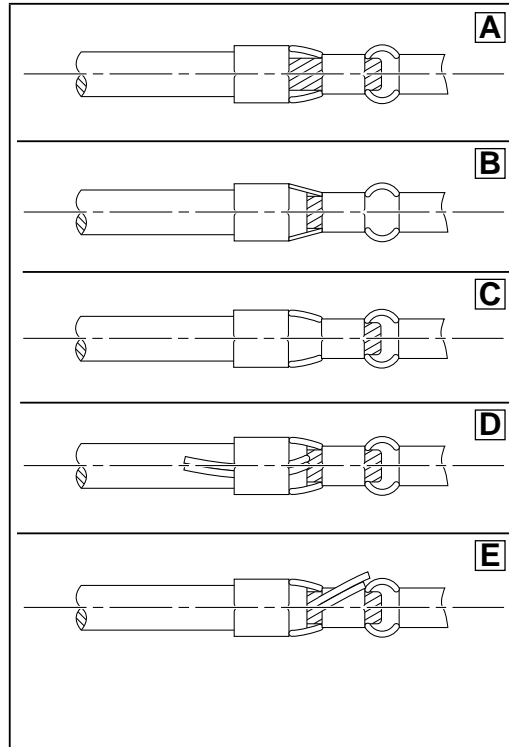

6

Mounting the cable socket res. the cable plug

- 1** Fasten the cable with the crimped leads (crimp barrel (D) or crimp plug (B) as shown in illustration) with the cable clip (E).
- 2** Push the leads into the cable outlet res. the cable plug (A) until they engage.
- 3** Connect as follows:
The trip lines are marked with numbers on the insulation. The phases are marked with the colours black, blue, and brown.
Pin-No. 1 = cable strand black (1.5 mm²)
Pin-No. 2 = cable strand No. 4 (0.75 mm²)
Pin-No. 3 = cable strand blue (1.5 mm²)
Pin-No. 4 = cable strand No. 3 (0.75 mm²)
Pin-No. 5 = cable strand brown (1.5 mm²)
Pin-No. 6 = cable strand No. 1 (0.75 mm²)
Pin-No. 7 = cable strand No. 2 (0.75 mm²)
- 4** Screw down the form piece.

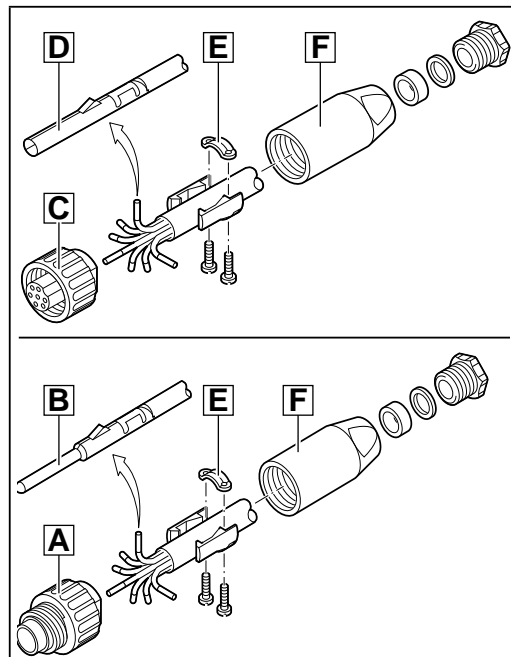

7

Loosening the crimp contacts

- 1** In case of wrong assignment insert the service tool to loosen crimp contacts and depress the hook of the respective crimp contact wire and pull it out at the same time.

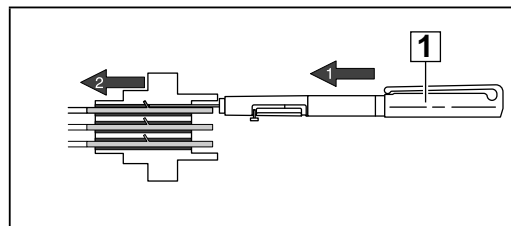

8